

Key Features

- Manufactured in Greensboro, North Carolina, USA.
- Heavy duty generator system designed for prime power operation in rental, construction and special events applications.

Skidbase and Enclosure

- Package foundation is a heavy duty, oilfield-ready skidbase designed with minimum 110% environmental containment to prevent any leakage of fuel, oil, or coolant.
- Optimized package design combines low noise levels with small footprint and full load performance capability in high ambient temperatures.
- The enclosure is coated with a 2 part epoxy over the zinc plated steel for superior corrosion resistance and a high gloss powder paint for long life.
- Wide opening side access doors are hinged, providing easy access and are equipped with recessed, pad-lockable handles.
- Package is equipped with a center-point lifting eye for safe, well-balanced hoisting, designed with a 5 x safety factor for the weight of a fully fueled unit with running gear.

Engine and Cooling System

- Industrial, heavy-duty diesel engine is emissions certified to current EPA requirements and provides optimum mix of performance and fuel economy.
- Electronically controlled engine provides isochronous frequency control and advanced diagnostic monitoring and protection.
- Oversized cooling system rated for high ambient tempera-

ture (minimum 40°C/104°F) operation without de-rating.

- The engine generator assembly is mounted on fail-safe vibration isolators.
- Coolant and oil drains are piped to bulkhead fittings mounted on the enclosure and all filters and maintenance points are easily accessed for safe and easy servicing.
- Engines are globally supported by the engine OEM and Clarke Power Generation, Inc.



Generator

- Leroy Somer alternators feature AREP brushless excitation providing industry leading motor starting kVA and 300% overload capability.
- Class H insulation with upgraded environmental coating for ultimate resistance to high temperature and humidity.
- Three position Voltage Selector Switch (VSS) to easily configure the units for operation at most common voltages.

| Voltage / Frequency | P.F. | Armature Connection | Rating | Amps | kW | kVA |
|---------------------|------|---------------------|---------|---------|-----|-----|
| 480V-3Ø-60Hz | 0.8 | Series Wye | Prime | 140 | 93 | 116 |
| | | | Standby | 155 | 103 | 129 |
| 240V-3Ø-60Hz | 0.8 | Parallel Wye | Prime | 277 | 93 | 116 |
| | | | Standby | 310 | 103 | 129 |
| 208V-3Ø-60Hz | 0.8 | Parallel Wye | Prime | 202 | 93 | 116 |
| | | | Standby | 358 | 103 | 129 |
| 240V-1Ø-60Hz | 1.0 | Zig-Zag | Prime | 304 | 73 | 73 |
| | | | Standby | 338 | 81 | 81 |
| 120V-1Ø-60Hz | 1.0 | Zig-Zag | Prime | 304 × 2 | 73 | 73 |
| | | | Standby | 338 × 2 | 81 | 81 |

Control System

- Digital control provide at-a-glance monitoring and simple access of vital engine and generator parameters. Micro-processor-controlled startup at the push of a button and protects the generator system from an array of faults while providing the operator with clear communication.
- Engine fault codes are displayed on the main LCD display, providing operators and technicians with a numeric and text explanation of the fault code, minimizing the need for expensive hand-held code scanners.
- Standard remote Auto Start / Stop capability via two wire, closed contact logic, allows for connection to automatic transfer switchgear and other remote starting devices.
- Industry exclusive Voltage Selector Switch (VSS) protection feature prevents switching the VSS while generator is operating.
- Battery disconnect switch is mounted inside the enclosure.

Power Connections

- All controls and connection points are grouped at the rear of the unit for safety and operator convenience.
- Power cables are connected at an oversized five lug (L1 L2 L3 N PE) terminal board capable of accepting bare end cable or terminated cables.
- Convenience receptacle panel includes individual branch circuit breakers.

Fuel System

- Single fuel tank sized for 24 hour runtime is mounted within the skid base, providing double wall protection.
- Fuel tank mounted low in frame and centered to ensure balanced lifting and low center of gravity.
- The fuel filler is located within the containment basin, minimizing possible spillage.

- Standard Racor-style fuel / water separator and fine micron secondary fuel filter keep contaminants out of the system and increase reliability.
- The containment system features a three-inch drain plug for easy cleaning, and the fuel tank has a drain plug mounted behind the containment plug.
- Leak-proof fuel vents eliminate the potential for fuel purge during out-of-level conditions during transport and load / unload.
- Low fuel shutdown ensures the engines will not lose prime if they run out of fuel.

Running Gear

- Integrated running gear system mounts directly to generator skidbase providing an industry-best low center of gravity for safe, stable towing, on-road or off-road.
- Tandem axle torsion suspension with E-Z-Lube hub assemblies and choice of electric or hydraulic surge brakes.
- All models feature high quality, grommet-mount lighting and meet Federal Motor Vehicle Safety Standards for lighting and conspicuity.
- Trailer-to-vehicle connector is a 6-pole round plug with a high quality, jacketed wiring harness.
- All units are equipped with a 3-inch pintle eye, wheel chocks and a high quality, heavy-duty jack stand.

Warranty

- All models are covered by a comprehensive limited warranty:
- Package: 1 year / 2000 hours
- John Deere Engine: 1 year / unlimited hours or 2 years / 4000 hours
- Leroy Somer Alternator: 2 years / 4000 hours

RC115D-T3 *Mobile Prime Generators*

| Engine Data | | |
|------------------------------|----------------------------|--------------|
| Engine Manufacturer | John Deere | |
| Model Number | 4045HF285 | |
| Prime Output @ Rated Speed | 144 HP | 107 kWm |
| Standby Output @ Rated Speed | 158 HP | 118 kWm |
| Engine Type | Inline 4-cycle | |
| Engine Control | ECU | |
| Emissions Certification | EPA Tier 3 | |
| Number of Cylinders | 4 | |
| Aspiration | Turbocharged / Intercooled | |
| Bore × Stroke | 4.2 × 5.0 in | 106 × 127 mm |
| Displacement | 275 in ³ | 4.5 L |
| Compression Ratio | 17 : 1 | |
| Governor Type | Electronic / Isochronous | |
| Speed Regulation Accuracy | + / - 0.25% Steady State | |
| Single Step Load Acceptance | 100% | |
| Cooling System | 50% Glycol / 50% Water | |
| Charging Alternator Output | 70 A | |
| DC System Voltage | 12 V | |
| Battery Output | 1000 CCA | |

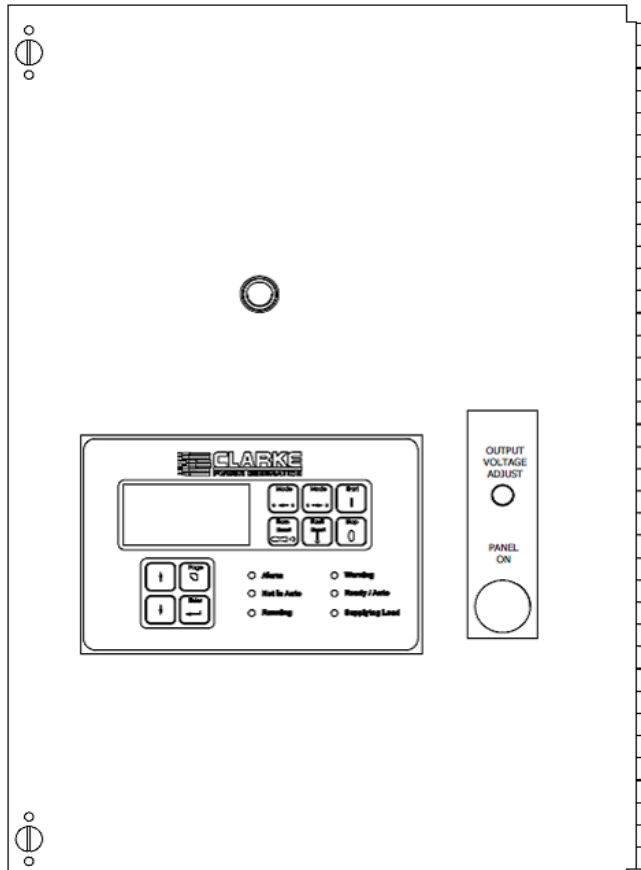

| Fluid Capacities | | Gal | L |
|--|---------|----------------------------|-----------|
| Oil Sump Capacity | | 3.57 | 13.5 |
| Cooling System Capacity | | 7.5 | 28.4 |
| Usable Fuel Cell Capacity | | 171.6 | 649.6 |
| Fuel Consumption | Gal / h | L / h | Runtime |
| @ 25% Load | 2.3 | 8.7 | 74.6 |
| @ 50% Load | 4.3 | 16.3 | 39.9 |
| @ 75% Load | 6.0 | 22.7 | 28.6 |
| @ 100% Load | 7.5 | 28.4 | 22.9 |
| Alternator Data | | | |
| Alternator Manufacturer | | Leroy Somer | |
| Alternator Model | | LSA 442 S7 | |
| Alternator Type | | Four Pole Revolving Field | |
| Number of Leads | | 12 | |
| Insulation Class | | H | |
| Frequency | | 60 Hz | |
| Available Voltages—3Ø | | 208 / 240 / 416 / 480 V | |
| Available Voltages—1Ø | | 120 / 139 / 240 / 277 V | |
| Voltage Connection Method | | 3-Position Selector Switch | |
| Excitation Method | | Brushless with AREP | |
| Voltage Regulator Model | | R438 | |
| Voltage Regulation Accuracy | | + / - 0.5% Steady State | |
| Total Harmonic Distortion (THD) | | <5% @ No Load | |
| Telephone Influence Factor (TIF) | | <50 | |
| Power Connections | | | Qty |
| 20A—125V GFCI Duplex (NEMA 5-20R) | | | 2 |
| 50A—125/250V Temp Power (CS6369) | | | 3 |
| Terminal Board Maximum Cable Size (Bare Wire) | | 350 MCM | |
| Terminal Board Maximum Cable Size (Lugged) | | 350 MCM | |
| Reference Conditions | | | |
| Rated Ambient Temperature | | 10°-104°F | -12°-40°C |
| Minimum Starting Temperature (Standard) | | 10°F (-12°C) | |
| Minimum Starting Temperature (w/ Cold Start Opt) | | 0°F (-18°C) | |
| Rated Altitude | | | |
| Temperature De-rate Factor | | | |
| Altitude De-rate Factor | | | |

RC115D-T3 *Mobile Prime Generators*

| | | |
|---|---|------------------------|
| Running Gear | To 49CFR571 requirements | |
| Configuration | Tandem axle | |
| Suspension | Torsion bar | |
| Standard Brake System Configuration | Electric (hydraulic surge brakes optional) | |
| Tires | ST205/75D15 | |
| Wheels | 15" x 6" (381 mm x 152 mm), 6 lug on 5.5" (140 mm) bolt circle | |
| Lighting and Reflectors | Meets FMVSS 571.108 requirements | |
| Electrical Connection to Towing Vehicle | Six pole round plug | |
| Standard Coupling Connection | 3" (76 mm) Pintle eye (2-5/16" (59 mm) ball coupler optional) | |
| Hitch Height | 20-22-24-26-28 in | 508-559-610-660-711 mm |
| Safety Chains | 2 x 5/16" (8 mm) Chains with slip hooks and safety latches | |
| Jack Stand Configuration | 5,000lb (2,268 kg) Capacity, top wind with sand shoe, trunion mounted | |
| Weights & Dimensions (w/ Running Gear) | | |
| Length | 165.8 in | 4,212 mm |
| Width | 71.7 in | 1,820 mm |
| Height | 83.6 in | 2,123 mm |
| Weight (Shipping) | 5,758 lb | 2,612 kg |
| Weight (Ready to Run) | 7,220 lb | 3,275 kg |
| Weights & Dimensions (Less Running Gear) | | |
| Length | 107.1 in | 2,721 mm |
| Width | 47.8 in | 1,214 mm |
| Height | 69.4 in | 1,764 mm |
| Weight (Shipping) | 4,865 lb | 2,207 kg |
| Weight (Ready to Run) | 6,327 lb | 2,870 kg |
| Sound Level @ 23ft (7m), 100% Load | 71 dB(A) | |

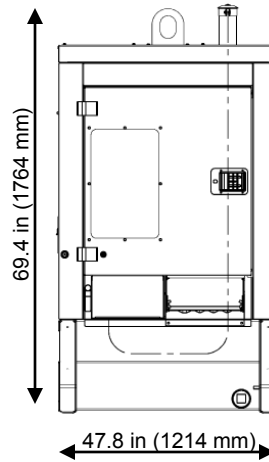
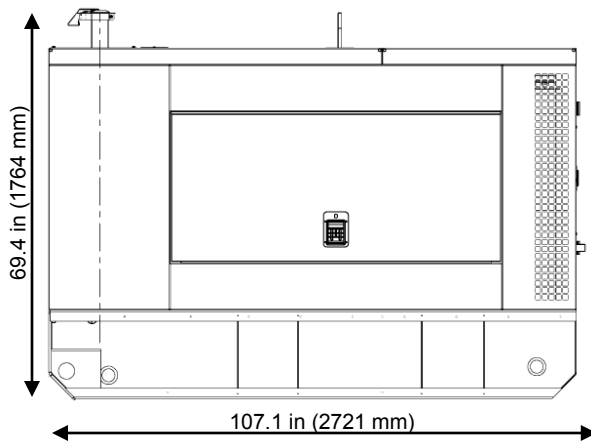
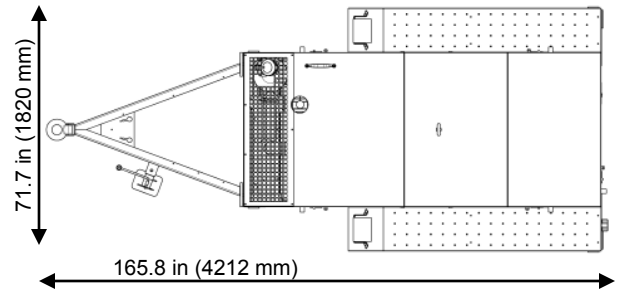
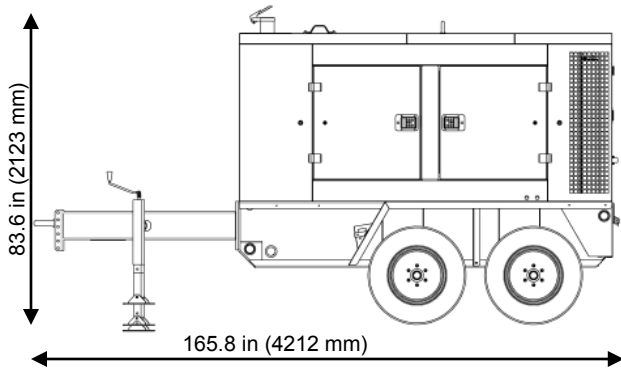

CLARKE[®]



Power Generation, Inc.

Due to continuous product improvement, specifications subject to change without notice.

Clarke Power Generation, Inc.
8015 Piedmont Triad Pkwy.
Greensboro, NC 27409

866.334.4367
clarkegen.com

© 2014 Clarke Power Generation, Inc. G131728 REV A